



FILTERCHARGER[®] INJECTION PERFORMANCE KIT

— INSTALLATION MANUAL —

Nissan 300ZX

1990-1993

V6-3.0L

Standard & Twin Turbo

P/N 57-6001

CARB E.O. # D-269-3

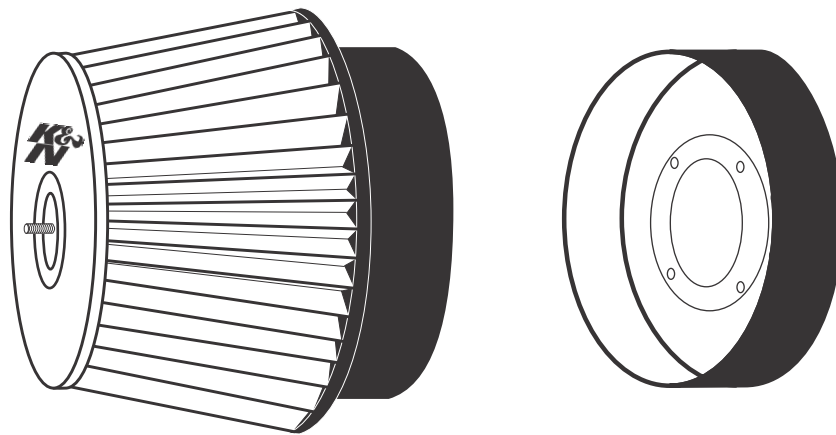

K&N Engineering, Inc.

561 Iowa Avenue

P.O. Box 1329

Riverside, CA 92502

K&N Filtercharger® Injection Performance Kit #: 57-6001

Application: 1990-93 Nissan 300ZX V6-3.0L engine non-turbo and twin turbo

Air-flow sensing device: hot-film air flow meter

BASIC DESIGN CONCEPT

This K&N Filtercharger® Injection Performance Kit (hereafter referred to as: **FIPK**) is designed to be less restrictive than the OEM air filter system. Low restriction air filters allow the engine to have better throttle response as well as more power throughout the RPM band. K&N has designed this **FIPK** to exactly replace the OEM factory air cleaner case, with a precision engineered aluminum adapter and all the necessary mounting brackets, bolts, screws and nuts. Additionally, it is important to note, if the O.E.M. air cleaner case has emission control devices and/or hoses, that all these parts will be installed as necessary to the new assembly.

Each **FIPK** has a specially designed filter with woven cotton fabric sandwiched between 2 layers of wire mesh screen. The screen and fabric combination creates a grid-like effect which actually straightens out the incoming air as it passes through the filter. In addition to the filter, this kit has a uniquely designed adapter with a built-in velocity stack. This velocity stack is beneficial in further smoothing out the incoming air flow and allowing for a less restrictive entry into the engine. (Air moving in a straight direction moves faster than tumbling air thus creating an increase in air flow). See the figure below.

AIR CLEANER DESIGN EFFECTIVENESS

To design an effective performance air filter assembly, two factors must be considered: the air filtering element and the air filter adapter. On fuel injected, computer controlled vehicles, there can be a substantial gain in performance by using a less restrictive air filter assembly. Original equipment air filter assemblies tend to be more restrictive than the performance enthusiast would like, therefore, by changing to the less restrictive K&N **FIPK**, the air flow potential of the engine can be fully maximized without jeopardizing important emission standards. (see figures below)

EMISSIONS LEGAL

The **FIPK** is street legal for use on the emission controlled vehicles that it was originally designed to fit. These kits replace the original air filter case and do not eliminate the emission controls. The high temperature label, (attached) contains the EO # assigned by C.A.R.B. that will allow a vehicle installed with the FIPK to pass the visual inspection at an authorized Smog Inspection station.

BEFORE F.I.P.K.

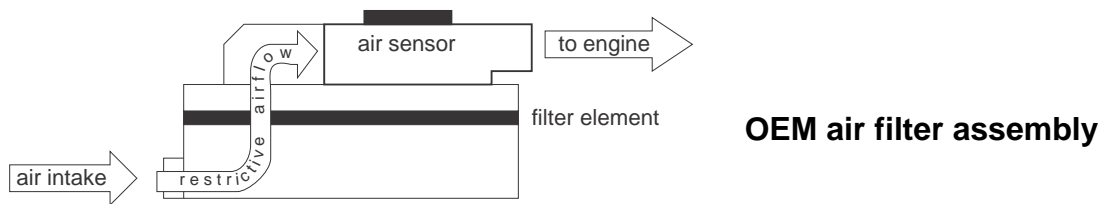

AFTER F.I.P.K.

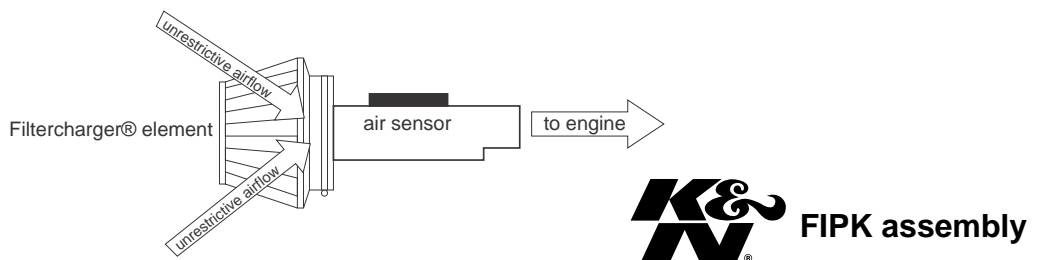

INSTALLATION INSTRUCTIONS

CAUTION!! PLEASE READ CAREFULLY AND COMPLETELY BEFORE BEGINNING WORK ON YOUR VEHICLE. K&N suggests that you have a repair manual available for reference during installation of the K&N Filtercharger® Injection Performance Kit.

NISSAN 300ZX ENGINE COMPARTMENT

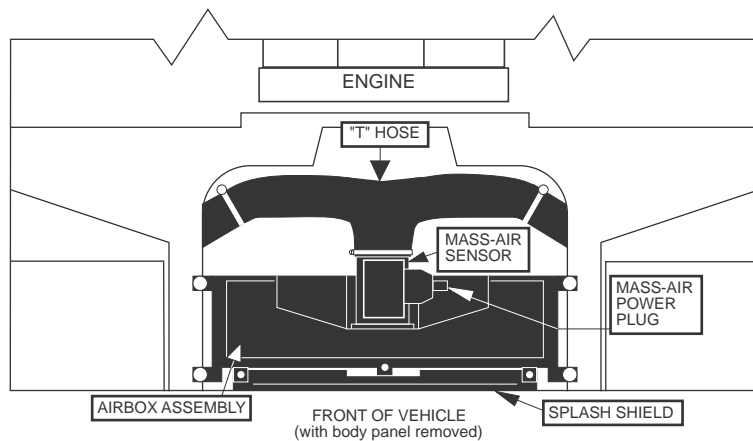

INSTALLATION

- 1) Disconnect the vehicle's negative battery cable.
- 2) Remove the body panel that covers the airbox. It is held in place by 4 bolts and most likely, there will be body shims used to make this panel line up with the hood. Be sure to note the location of the shims.
- 3) Unhook the clips and remove the 3 phillips screws holding the airbox lid on.
- 4) Loosen the hose clamp where the "T" hose connects to the mass-air sensor.
- 5) Loosen the remaining 2 hose clamps on the "T" hose.
- 6) Unclip the power plug at the mass-air sensor (held on by a small spring clip) and move it out the way for now. Be careful not to lose the spring clip.
- 7) Remove the airbox lid and the mass-air sensor as a unit.
- 8) Remove the filter elements and the "T" hose from the vehicle.
- 9) Remove the 6 bolts holding the airbox base into the vehicle. (see fig. 1)
- 10) Carefully remove the airbox by pushing one side down, past shield, then rotate out. It is a tight fit, so work patiently. Leave the intake snorkels mounted in the vehicle.
- 11) Remove the mass-air sensor from the airbox lid (held in place by 4 bolts).
- 12) Bolt the filter adapter and the "L" brackets to the mass-air sensor with the supplied hardware. Do not completely tighten at this time. (see fig. 2)

fig. 1

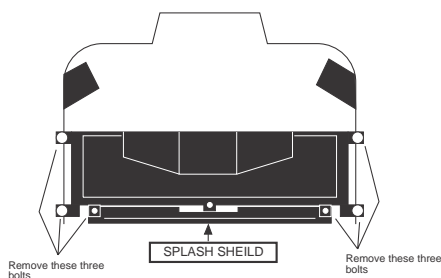

fig. 2

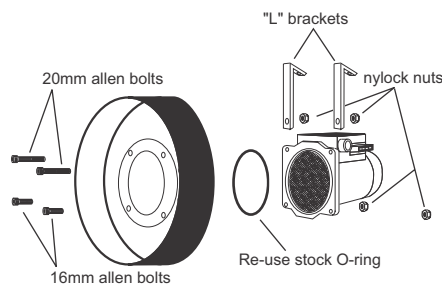
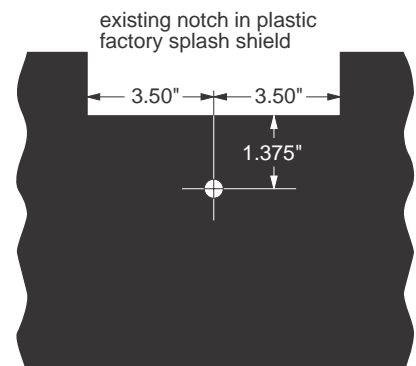

fig. 3



- 13) Drill a 1/4" diameter hole in the plastic splash shield. (see fig. 3)
- 14) Bolt the K&N Filtercharger to the splash shield with the supplied hardware. (see fig. 4)
- 15) Install the "T" hose back into vehicle, but do not tighten the hose clamps at this time.
- 16) Install the mass-air / adapter assembly into the "T" hose and snug the clamp gently.
- 17) Install the straight brackets into the vehicle with supplied hardware. (see fig. 5) **NOTE: to service the Filtercharger element, remove one of the straight brackets, then the filter can be removed.**
- 18) Tighten all of the bolts at this time. See fig. 6 for proper sequence.
- 19) Install the K&N Filtercharger® onto the adapter, be careful not to over-tighten hose clamp!
- 20) Tighten the 3 hose clamps on the "T" hose.
- 21) Plug the power plug back into the mass-air sensor. Be certain that the spring clip is installed properly on the plug.
- 22) Re-connect the battery cable. Double check to make sure everything is tight and properly positioned before starting vehicle.
- 23) Re-install the body panel. If there were body shims, be sure they are in the proper location.
- 24) The C.A.R.B. exemption sticker, (attached) must be placed in a visible area under the hood, so that an emissions inspector can see it when the vehicle is required to be tested for emissions. California requires testing every two years, other states may vary.

fig. 4

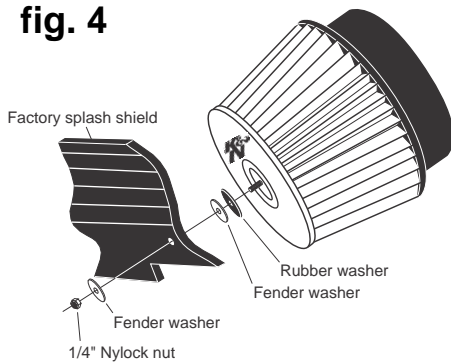

fig. 5

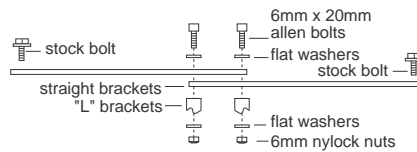
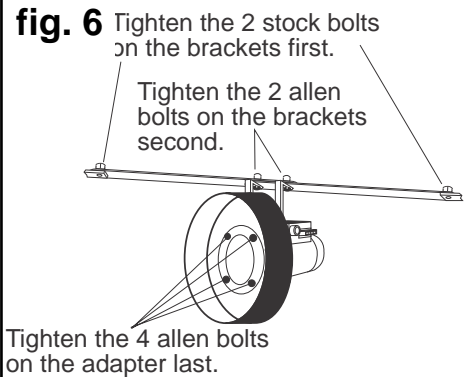

fig. 6



ROAD TESTING

Start the engine with the transmission in neutral or park, and the emergency brake on. Listen for any air leaks or odd noises. If there are air leaks, make sure the hose connections are secure. If there are any odd noises, check for the cause and repair before proceeding. The K&N Filtercharger® Injection Performance Kit will function identically to the factory air filter with the exception of being slightly louder than stock and much more responsive. If all preliminary checks are okay, then a road test is necessary. Listen carefully for rattling or other odd noises and fix as necessary. If the road test is fine, you can enjoy driving as normal with the added response and power. We suggest that the Filtercharger® element be checked periodically for dirt. This is now very easy due to the open element configuration. If the filter material is overly dirty, service it according to the instructions that are in the Recharger service kit that was included with the FIPK. If you have any questions or problems, inquire at your nearest K&N dealer, or direct to K&N Engineering at (909) 684-9762.

PARTS LIST

	description	quantity
A	6mm-1.00 x 16mm allen bolt	2
B	6mm-1.00 x 20mm allen bolt	4
C	6mm-1.00 nylock nut	6
D	1/4-20 nylock nut	1
E	fender washer	2
F	flat washer	4
G	rubber washer	1
H	"L" bracket	2
I	straight bracket	2
J	die-cast filter adapter	1
K	size 104 hose clamp	1
L	Filtercharger® element	1

