

**PLEASE READ THESE INSTRUCTIONS CAREFULLY BEFORE FITTING THIS KIT**

**If you have a problem, however small, call our Technical Department**

Tel:- 01925 636950. Fax:- 01925 418948. Monday to Friday 9am - 5pm

**Drawing A**

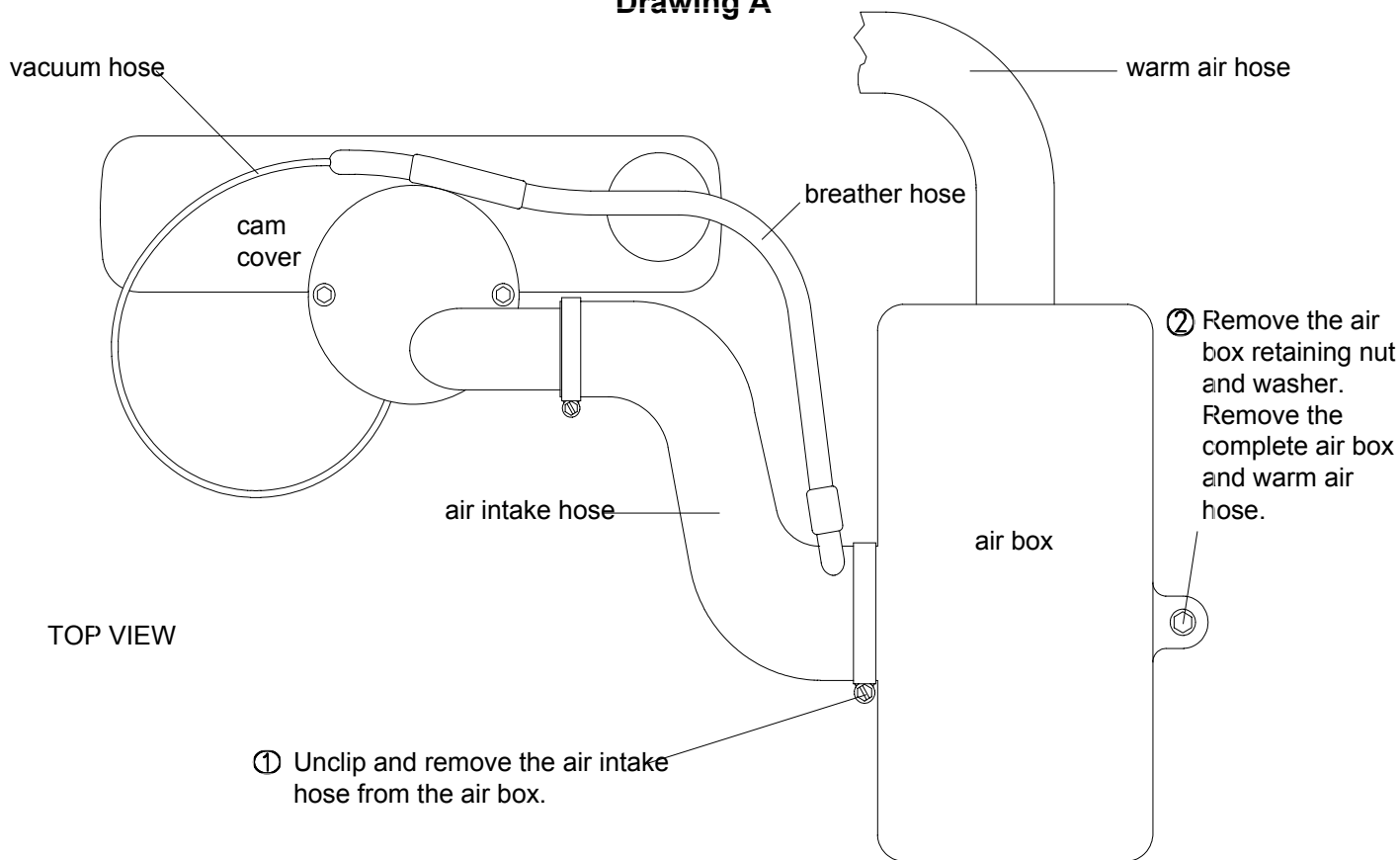

**Drawing B**

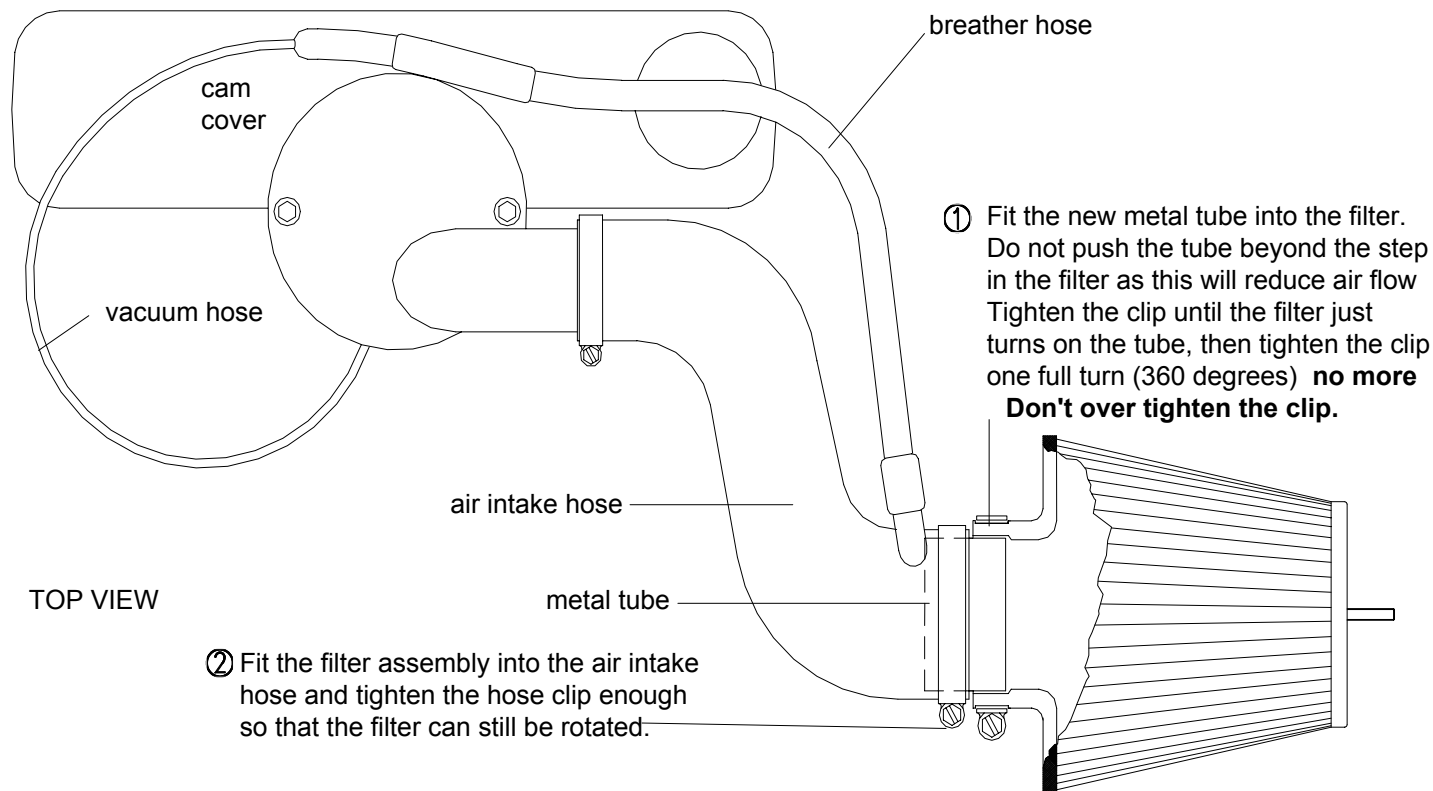

FRONT VIEW

① Rotate the filter until the offset is at the bottom the firmly tighten the clip.

② Fit the mounting bracket to the existing air box securing stud. Fit and tighten the original retaining nut and washer.

③ Secure the filter to the bracket with the M6 nut and spring washer.

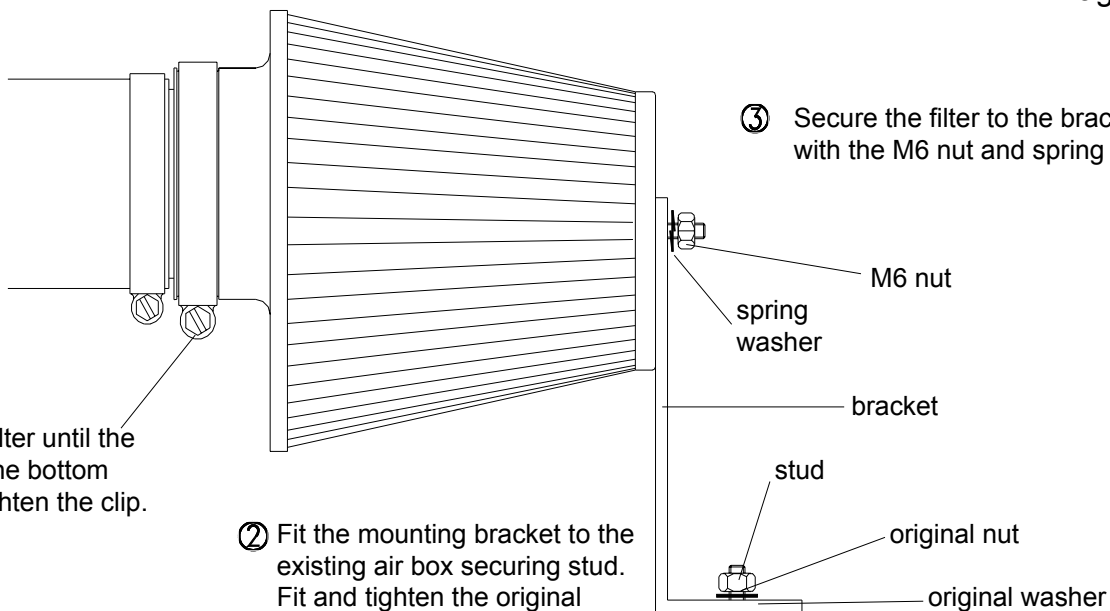

**Drawing D**

① Carefully lengthen the flexi cold air hose to approx. 48cm / 19"

② Feed the cold air hose down behind the radiator top hose to the bottom of the engine bay.

③ Position the top of the cold air hose to finish approx. 10cm/4" away from the filter and secure to the radiator top hose using the long plastic tie supplied.

FRONT VIEW

radiator top hose

10cm/4"  
no nearer

flexi cold air hose

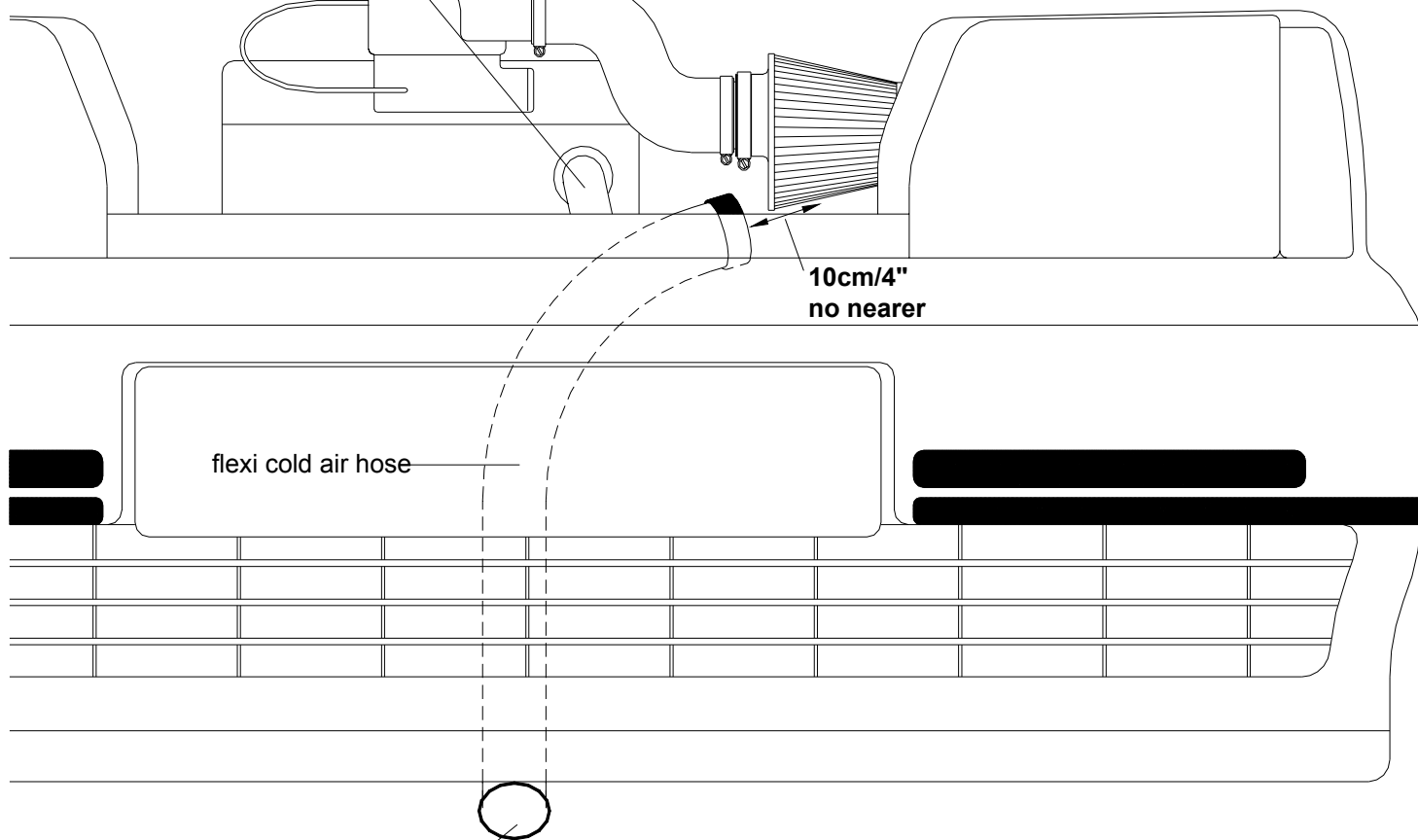

④ Ovalise the lower end of the flexi cold air hose and position it at the front of the car just below the front lower bumper.

⑤ Tie the hose to the radiator bottom hose using the second long plastic tie supplied.

**Tuning.****CAT. Cars** No adjustments required

An increase in fuel mixture may be required if further modifications are carried out.

**Filter Maintenance.**

Under normal conditions clean and reoil the filter at approx. 40,000 miles / 65,000km.

**Use only K&N cleaner and oil** and follow the instructions carefully.**K&N filters are pre-oiled ready to fit****The advantage of K&N's cold air intake system.**

Cooler air being denser, will show positive improvements in power over filter systems that draw hot air from the engine bay.

This Kit Should Contain:

- 1 x Clamp On Filter
- 1 x Cold Air Hose Assembly
- 1 x Instruction Sheet
- 1 x Instruction Pack :-
  - 1 x K&N window sticker
  - 1 x Filter Maintenance Sheet
  - 1 x Million Mile Warranty
  - 1 x Leaflet
- 1 x Fixing Kit :-
  - 1 x M6 x 5 Nut
  - 1 x 6mm Spring Washer
  - 2 x Long Cable Ties
  - 1 x Metal Tube
  - 1 x Bracket
  - 1 x Clamp #48

**FITTING YOUR OWN 57i KIT**

If not **it is essential** that the person fitting the kit (e.g. mechanic) **carefully follows these particular instructions** even if he has fitted K&N kits before. This will save you both time and money. kits incorrectly fitted may show a loss in performance e.g. the positioning of the essential cold air hose, (flexi expandable and rubber hoses are used).

**A final check** under the bonnet, by yourself with the instructions, would seem sensible