

**PLEASE READ THE INSTRUCTIONS CAREFULLY BEFORE FITTING THE KIT.**

**If you have a problem, however small, call our Technical Department.**

Tel:- 01925 636950. Fax:- 01925 418948. Monday to Friday 9am - 5pm.

- 1 Push in spring clip and remove the plug on the Mass Air Sensor (**MAS**), (attached to the air box)
- 2 Press the spring clip and release the clip from the black sensor on the side of the air box. Lift out spring clip and pull out black sensor.
- 3 Remove the two 'O' rings holding down the air box. Release the heavy duty clamp on the inlet hose using large vice grips, **take care**.
- 4 Remove the **MAS** from the intake hose and release the sensor cable from the air box lid. Remove the air box lid and air box base.
- 5 Remove the **MAS** from the air box.
- 6 Fit the new intake flange to the **MAS** using the three short screws, washers and nuts supplied, **Drawing A**. Fit the bracket to **MAS** using the long screw.
- 7 Fit the **MAS** back into the intake hose, don't fit the clamp yet.
- 8 Fit the bracket to the top stud on the suspension turret, using the original nut. Attach the other end of the bracket to the **MAS** using the long screw **Drawing B**.
- 9 The clamp can now be fitted on the intake hose.
- 10 Fit the filter to the new flange, positioning the K&N logo straight. **Don't overtighten clip**. Push the black sensor into the small hole in the filter base and replace the spring clip. **Drawing C & D**.
- 11 **Cold air intake system.**
- 11.1 Raise the offside of the car, **taking all the necessary safety precautions**.
- 11.2 **Drawing E**. Reposition horn to provide clearance for flexi hose.
- 11.3 **Carefully** expand the hose to approx. 16" / 40cm. Attach the top section of hose to the cable support using a long plastic tie. Finish hose 4" / 10cm from the filter, **NO NEARER**.
- 11.4 Feed the hose downwards and position as **Drawing C,E & F**.
- 12 **Tuning.**  
**CAT. Cars.** No adjustments are required.  
An increase in fuel may be required if further engine modifications are to be carried out.
- 13 **Filter maintenance.**  
Under normal conditions clean and re oil the filter at approx. 40,000 miles / 65,000 Km.  
**Use only K&N Cleaner** and oil and follow the instructions carefully.

**K&N Filters are pre oiled ready to fit.**

**The advantage of K&N's cold air intake system**

Cooler air, being denser, will show positive improvements in power over filter systems that draw hot air from the engine bay.

**This kit should contain:-**

- 1 x Clamp-on Filter
- 1 x Cold Air Hose Assembly.
- 1 x Instruction Sheet.
- 1 x Instruction Pack:-
  - 1 x Filter Maintenance Sheet.
  - 1 x K&N Window Sticker.
  - 1 x Million Mile Warranty Card.
  - 1 x Leaflet
- 1 x Fixing kit containing :-
  - 1 x M6 x 20 Hex Screw.
  - 3 x M6 x 16 Hex Screws.
  - 4 x 6mm Spring Washers.
  - 4 x M6 Hex Nuts.
  - 2 x Plastic Cable ties (10cm long).
  - 1 x Plastic Cable tie (35cm long).
  - 1 x Hose Clip #60
  - 1 x Bracket.
  - 1 x Adapter Tube.

**IMPORTANT INSTRUCTIONS  
FOR ROUND ENTRY  
CLAMP ON AIR FILTERS**

Gently tighten the hose clip to the point where the filter will just rotate on the pipe or intake flange. Reposition the K&N logo straight, then **give the clip two turns i.e. 360 , no more.**

**FITTING YOUR OWN 57i KIT**

If not, **it is essential** that the person fitting the kit (e.g. mechanic) **carefully follows these particular instructions** even if he has fitted K&N kits before. This will save you both time and money. Kits incorrectly fitted may show a loss in performance e.g. the positioning of the essential cold air hose, (flexi expandable and rubber hoses are used).

**A final check** under the bonnet, by yourself, with the instructions, would seem sensible.

### Drawing A

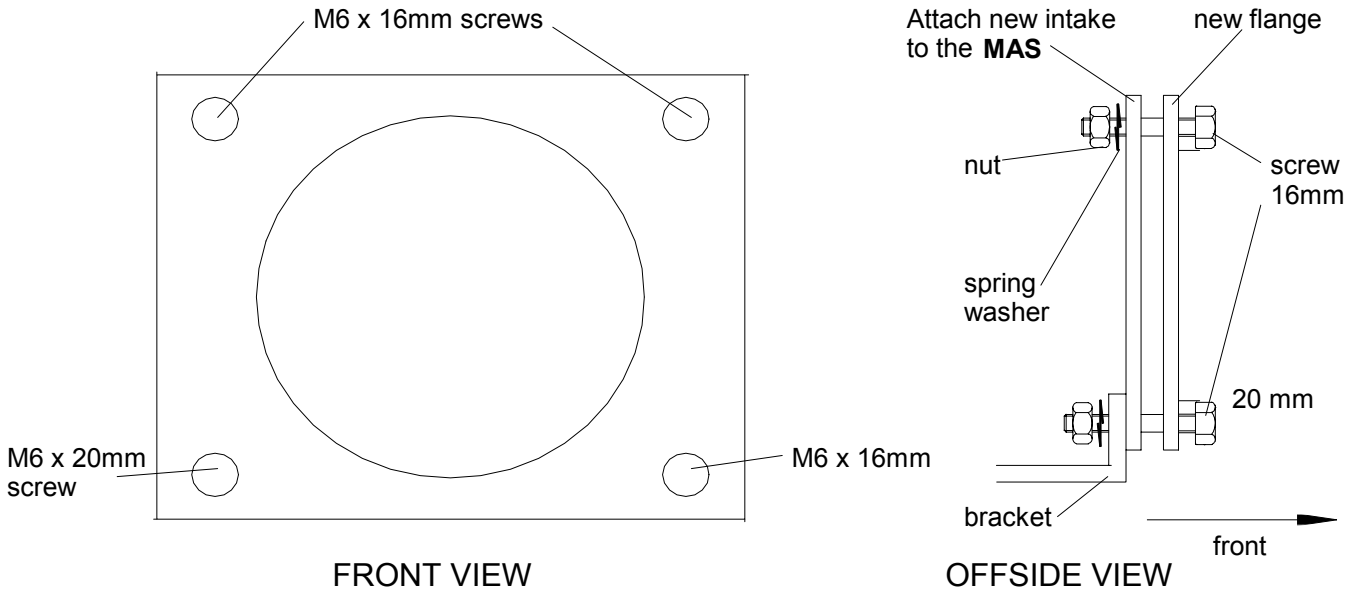

### Drawing B

### Drawing C

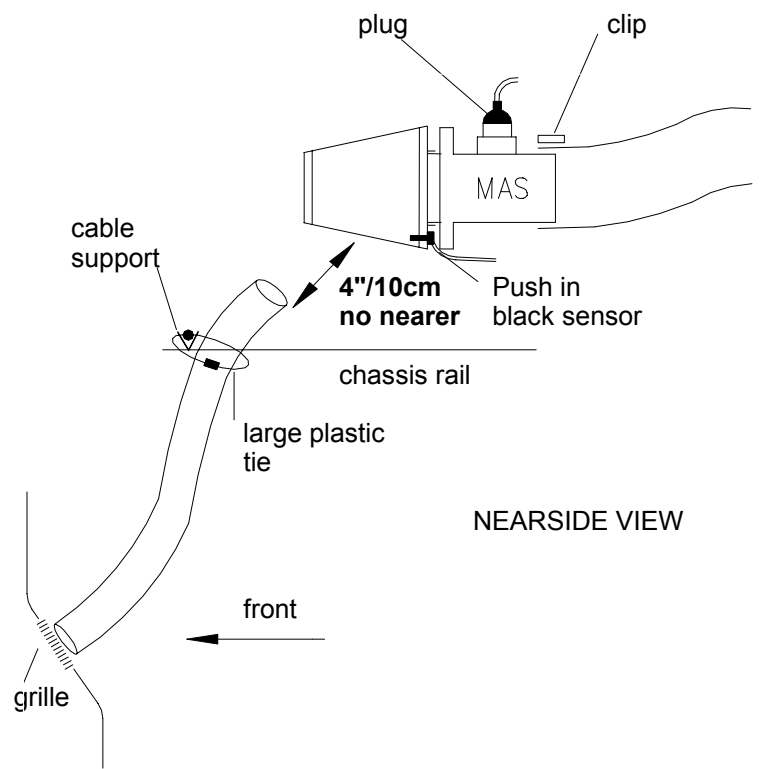
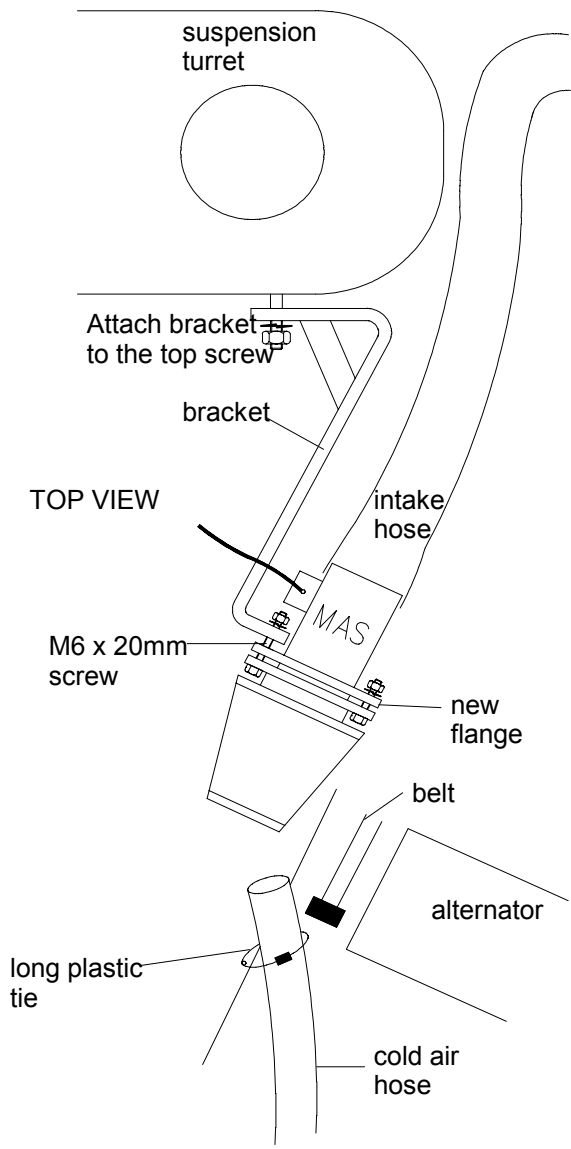

### Drawing D

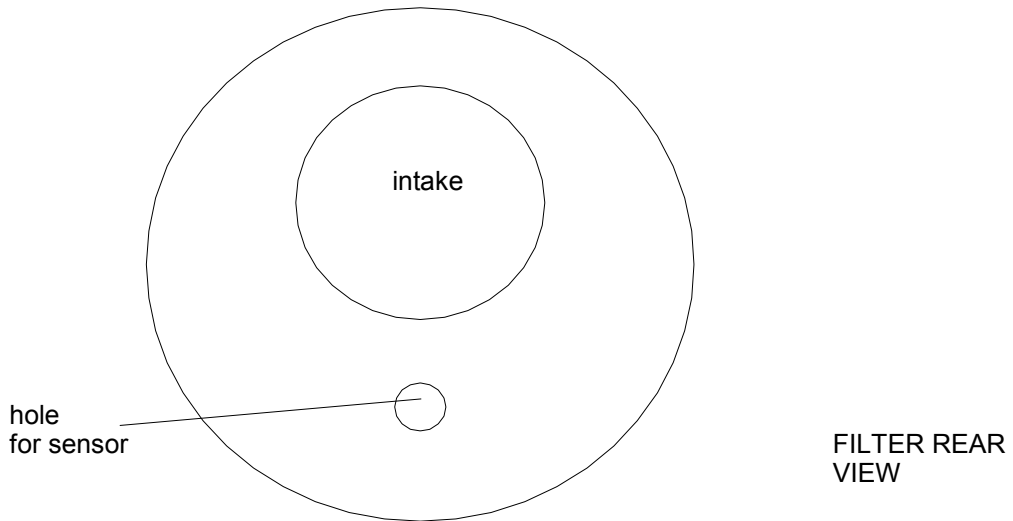

### Drawing E

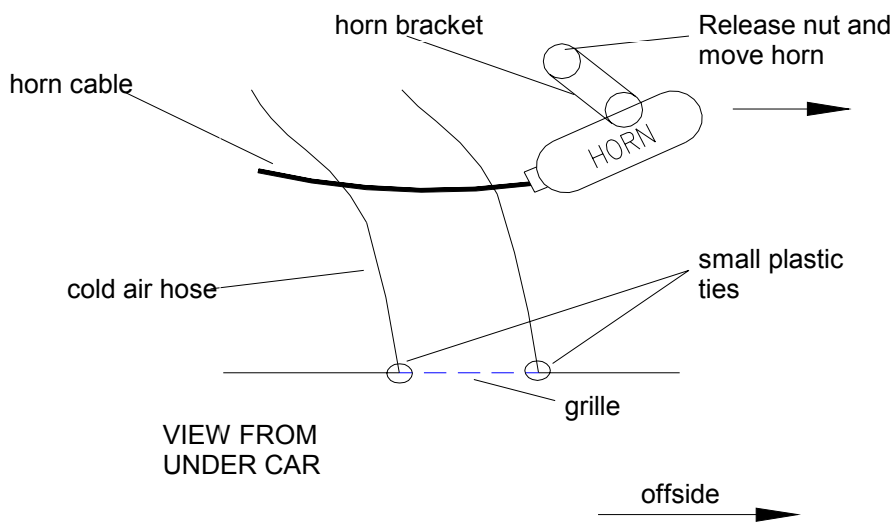

### Drawing F

