

**PLEASE READ THE INSTRUCTIONS CAREFULLY BEFORE FITTING THE KIT.****If you have a problem, however small, call our Technical Department.**

Tel:- 01925 636950. Fax:- 01925 418948. Monday to Friday 9am - 5pm.

- 1 Release the intake hose clip and remove the air box lid and filter.
- 2 Release (but don't remove) the two air box mounting nuts. **Lift up** the air box base and pull towards the engine. Remove the rubber sleeve from the front of the air box.
- 3 Repositioning the wiring looms and fit the rubber bobbin to the rear box mounting.  
**Drawing A.**
- 4 Fit the new metal tube fully into the intake hose and tighten the clip. Attach the bracket section to the rubber bobbin.
- 5 **Raise the front of the car taking the necessary safety precautions.** Remove the front nut on the suspension turret and fit the small two hole bracket replace nut and **tighten firmly.** Attach the small wiring loom to the new bracket, using a small plastic tie.  
**Drawing C**
- 6 Fit the filter to the metal tube, up to the bracket underneath. Keep the filter square to the tube. **Don't overtighten the hose clip.**
- 7 **Cold air system.**  
**Read this section fully before fitting the hose.**  
Carefully expand the flexi hose to approximately 23"/59cm. Ovalise one end to fit into the lower offside air intake. **Drawing C.**
- 8 Attach other end of the cold air hose to the plastic pipe using a long plastic tie but do not overtighten the tie, it may crush. **Drawing D.**
- 9 Position cold air hose as **Drawing E.**
- 10 **Tuning.**  
**CAT. CARS,** no adjustments are required.  
An increase in fuel may be required if additional tuning modifications are carried out.
- 11 **Filter maintenance.**  
Under normal conditions clean and reoil the filter at approx. 40,000 miles /65,000 Km.  
**Use only K&N Cleaner and oil** and follow the instructions carefully.

**K&N Filters are pre-oiled ready to fit.****The advantage's of K&N cold air intake system.**

Cooler air being denser, will show positive improvements in power over filter systems that draw hot air from the engine bay.

**This Kit Should Contain :-**

- 1 x Clamp-on Filter.
- 1 x Cold Air Hose Assembly.
- 1 x Tube.
- 1 x Instruction Sheet.
- 1 x Instruction Pack:-
  - 1 x Filter Maintenance Sheet.
  - 1 x K&N Window Sticker.
  - 1 x Million Mile Warranty Card
  - 1 x Leaflet.
- 1 x Fixing Kit Containing :-
  - 1 x Two Holed Bracket
  - 1 x Rubber Mounting.
  - 2 x  $\frac{5}{16}$ " UNF Nuts.
  - 2 x Metal Washers 8 x 25 x 1.5mm.
  - 2 x 8mm Spring Washers.
  - 1 x Plastic Tie (10cm long).
  - 2 x Plastic Ties (35cm long).
  - 1 x Hose Clip size 44.

**IMPORTANT INSTRUCTIONS  
FOR ROUND ENTRY  
CLAMP ON AIR FILTERS**

Gently tighten the hose clip to the point where the filter will just rotate on the pipe or intake flange. Reposition the K&N logo straight, then **give the clip two turns i.e. 360, no more.**

**FITTING YOUR OWN 57i KIT**

If not, **it is essential** that the person fitting the kit (e.g. mechanic) **carefully follows these particular instructions** even if he has fitted K&N kits before. This will save you both time and money. Kits incorrectly fitted may show a loss in performance e.g. the positioning of the essential cold air hose, (flexi expandable and rubber hoses are used).

**A final check** under the bonnet, by yourself, with the instructions, would seem sensible.

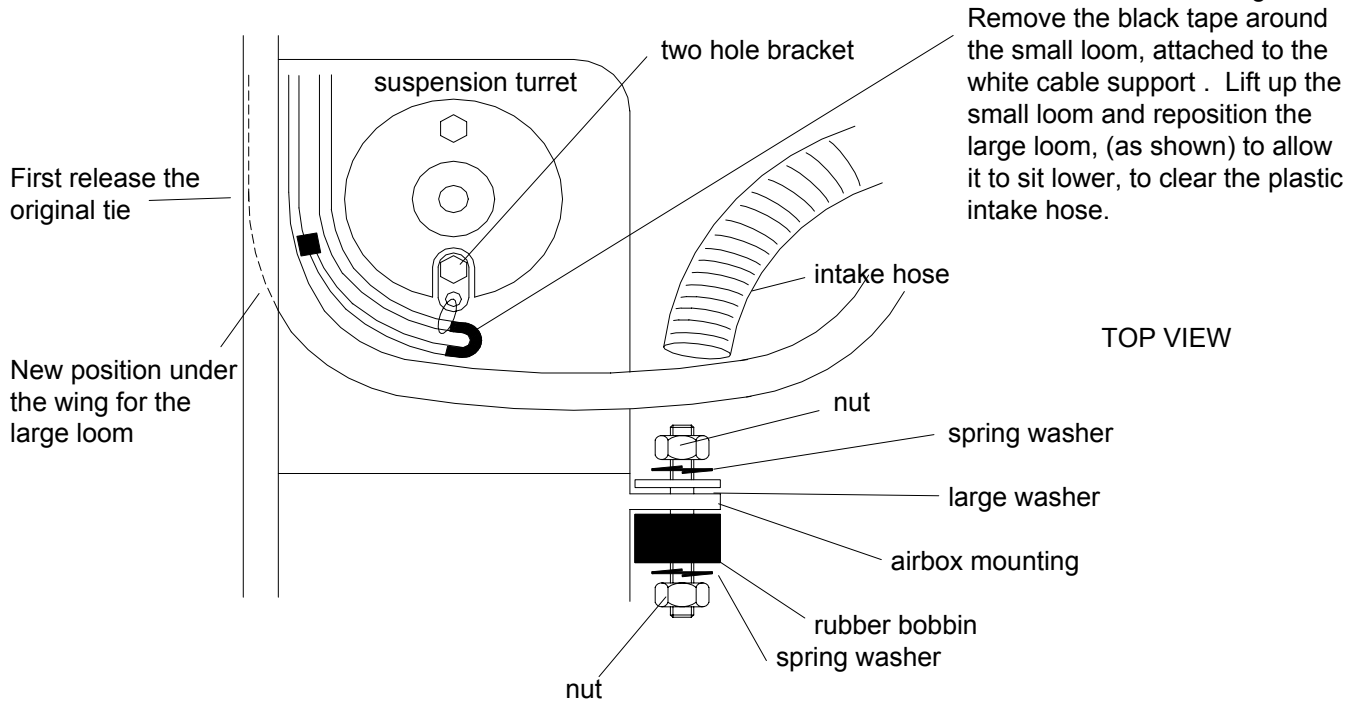

**Drawing B**

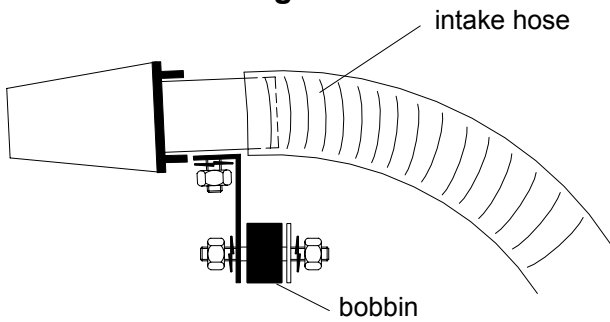

**Drawing C**

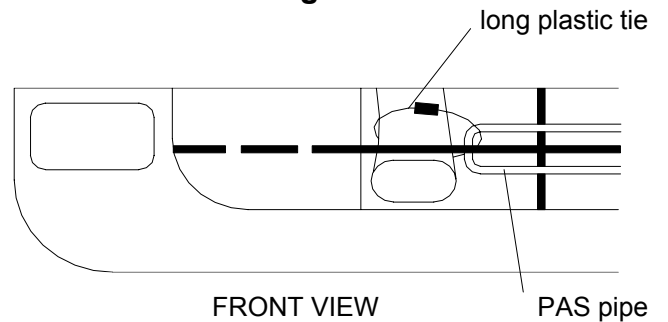

**Drawing D**

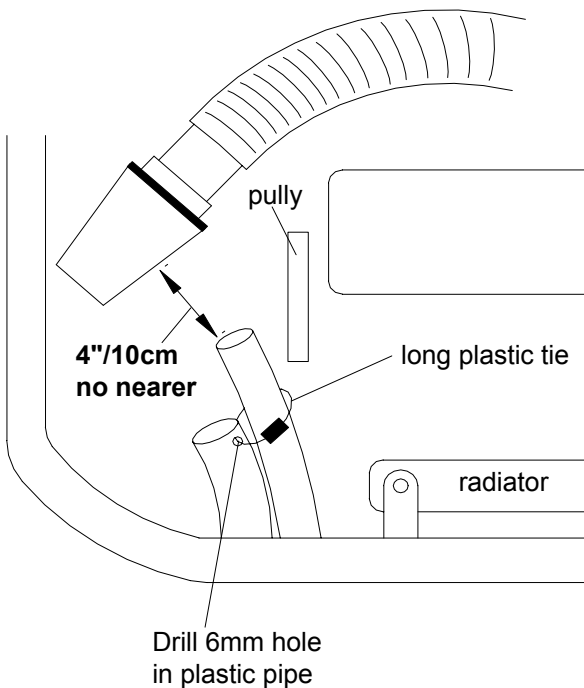

**Drawing E**

