

PLEASE READ THE INSTRUCTIONS BEFORE FITTING THE KIT**If you have a problem, however small, call our Technical Department.**

Tel:- 01925 636950. Fax:- 01925 418948. Monday to Friday 9am - 5pm.

- 1 Remove the complete air filter system including the air flow meter (**AFM**) and the front support bracket attached to the front panel. **Drawing A**. Leave the rear air box mounting in place in order to support the relay's etc.
- 2 Remove the **AFM** from the air filter box and fit the square adaptor using the gasket and four countersunk screws supplied.
- 3 Remove the breather hose from the plastic outlet on the timing belt cover. Fit the new rubber hose to sit on top of the alternator with the outlet on top. Any fumes emitted will be drawn into the filter.
- 4 Remove the lifting lug to the left of the alternator, and fit the new bracket (don't tighten yet). **Drawing B**.
- 5 Fit the **AFM** into the intake hose and attach the bracket to the **AFM** with the two screws supplied. The hose clip and screws can now be tightened. **Drawings C & D**.
- 6 Mount the filter onto the **AFM** adaptor with the K & N logo is straight before tightening the clip. Tighten the clip until the filter just moves, then give one full turn (360 degrees). **No more. Don't overtighten the clip.**
- 7 **Cold air system**
Carefully expand the flexi cold air hose to approximately 91cm / 36". Feed the hose downwards through the hole in the inner wing to the grille. **Drawings E & F**.
- 8 Secure the other end of the cold air hose to finish approximately **10cm / 4"** from the filter (**no nearer**). **Drawing C**.
- 9 **Tuning**
We suggest that a simple **CO** test is carried out, as some cars may be set weaker than the standard setting. The **CO** figure should not be set at more than **0.5%** above the recommended figure.
- 10 **Filter Maintenance**
Under normal conditions clean and reoil the filter at approx. 40,000 miles / 65,000 km. **Use only K&N cleaner and oil** and follow the instructions carefully.

K&N filters are pre oiled ready to fit**The advantages of K&N's cold air intake system**

Cooler air, being denser, will show positive improvements in power over filter systems that draw hot air from the engine bay.

This Kit Should Contain :-

- 1 x Clamp-on filter.
- 1 x Rubber breather hose
- 1 x Cold Air Hose Assembly
- 1 x Instruction Sheet
- 1 x Instruction Pack :-
 - 1 x K&N Window sticker
 - 1 x Filter Maintenance Sheet
 - 1 x Million Mile Warranty
 - 1 x Leaflet
- 1 x Fixing Kit :-
 - 1 x AFM Adaptor.
 - 1 x AFM adaptor gasket.
 - 2 x M8 x 16mm hex head screws.
 - 4 x M6 x 10mm C' Sunk screws.
 - 3 x Plastic cable ties (14" long).
 - 1 x #48 Hose clip.
 - 1 x Bracket.

FITTING YOUR OWN 57i KIT

If not, **it is essential** that the person fitting the kit (e.g. mechanic) **carefully follows these particular instructions** even if he has fitted K&N kits before. This will save you both time and money. Kits incorrectly fitted may show a loss in performance e.g. the positioning of the essential cold air hose, (flexi expandable and rubber hoses are used).

A final check under the bonnet, by yourself, with the instructions, would seem sensible.

Drawing A

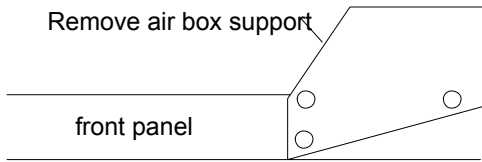

Drawing B

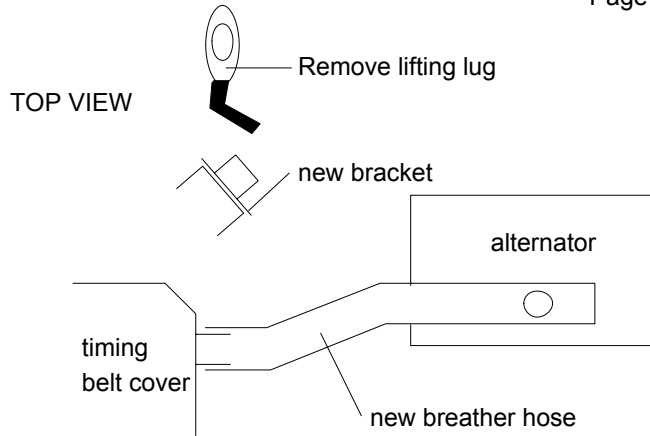

Drawing C

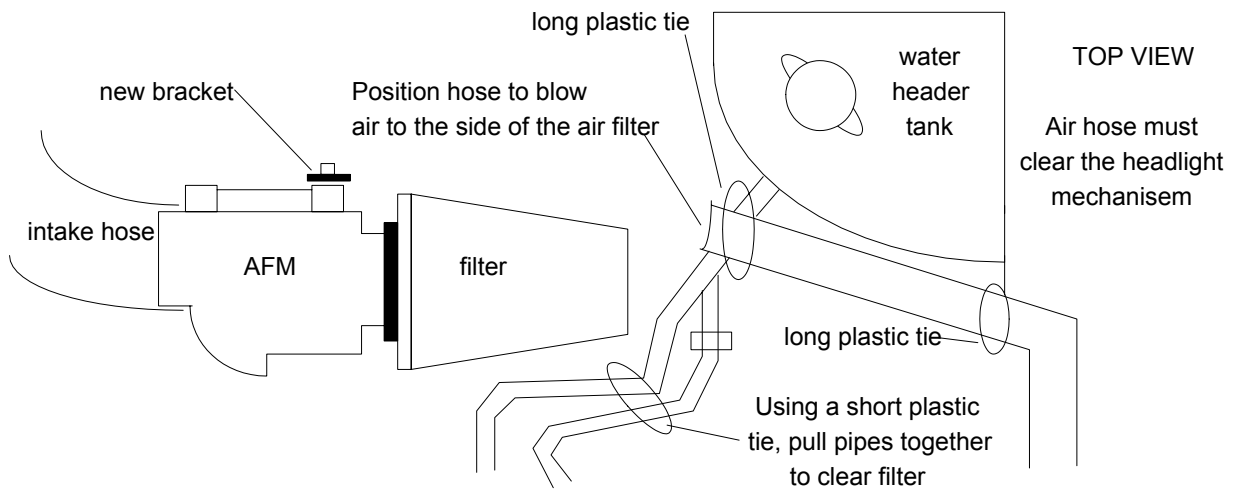

Drawing D

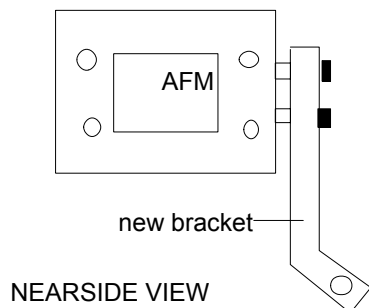

Drawing E

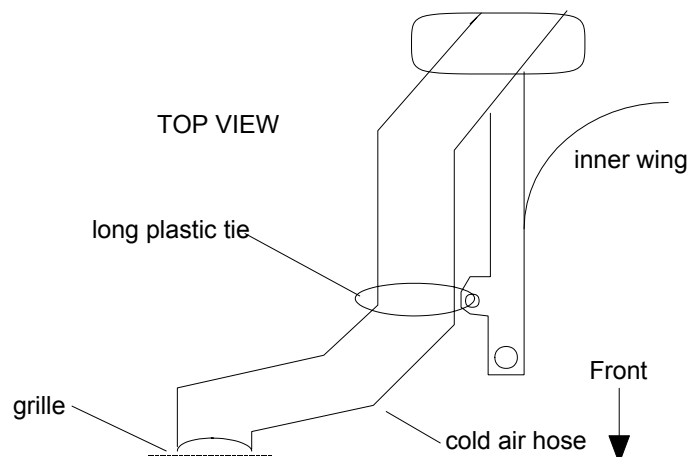

Drawing F

