

PLEASE READ THE INSTRUCTIONS BEFORE FITTING THE KIT
If you have a problem, however small, call our Technical Department.
Tel:- 01925 636950. Fax:- 01925 418948. Monday to Friday 9am - 5pm.

- 1 Remove the complete air filter system including the two air hoses.
- 2 Remove the breather hose from the outlet on the cam cover. Remove the short hose from the blue plastic reducer. Fit the new longer hose (supplied) to the blue reducer, then push the hose onto the breather outlet pipe.
- 3 **Drawing A.** Fit the black plastic pipe into the other end of the original hose. Fit the plastic pipe into the base of the filter.
- 4 **Fitting the filter**
Remove the rubber gasket, and check that the flange is clean and free of oil. Fit the filter with the "K&N" facing front. **IMPORTANT hold the filter down and tighten the hose clip gently until the filter can just be turned on the flange, tighten one full turn 360 no more.**
- 5 a) **Cold air system**
Carefully expand the flexi hose to approx. 33"/84cm. Fitting the new flexi hose will be made easier if the nearside of the car is raised up. **Take all the necessary safety precautions.**
 - b) Using a standard hacksaw blade cut the two plastic sections shown in **Drawing B**. Bend the plastic section towards the offside of the car, **Drawing C & D**. The plastic section will stay in position.
 - c) Remove the engine lifting bracket from the side of the cylinder head, providing more space for the cold air hose.
 - d) **Drawing E.** Feed the flexi hose down past the battery to finish in the nearside of the front grille. Attach the plastic ties as shown in **Drawings D & E**.
 - e) The cold air hose should finish 4"/10cm from the air filter, **no nearer**.
- 6 **Tuning.**
CAT. Cars, no adjustments are required.
- 7 **Filter maintenance**
Under normal conditions clean and reoil the filter at approx 40000 miles/65000 km. **Use only K&N cleaner** and oil and follow the instructions carefully.

K&N filters are pre oiled ready to fit

The advantages of K&N's cold air intake system

Cooler air, being denser, will show positive improvements in power over filter systems that draw hot air from the engine bay.

This Kit Should Contain :-

- 1 x Clamp-on filter.
- 1 x Cold air hose assembly.
- 1 x Instruction sheet.
- 1 x Instruction pack:-
 - 1 x Filter maintenance sheet.
 - 1 x K&N window sticker.
 - 1 x Million mile warranty card.
 - 1 x Leaflet.
- 1 Fixing Kit:-
 - 2 x Plastic cable ties (14" long).
 - 1 x Hose Clip 100/120
 - 1 x Plastic tube.
 - 1 x Rubber breather hose.

FITTING YOUR OWN 57i KIT

If not, **it is essential** that the person fitting the kit (e.g. mechanic) **carefully follows these particular instructions** even if he has fitted K&N kits before. This will save you both time and money. Kits incorrectly fitted may show a loss in performance e.g. the positioning of the essential cold air hose, (flexi expandable and rubber hoses are used).

A final check under the bonnet, by yourself, with the instructions, would seem sensible.

IMPORTANT INSTRUCTION FOR FITTING THE AIR FILTER.

Remove the seal, clean and degrease the flange. Check clip for correct position all round. Hold filter down then gently tighten until the filter will just turn on the flange. Give one full turn, **360 NO MORE.**

NEAR SIDE VIEW

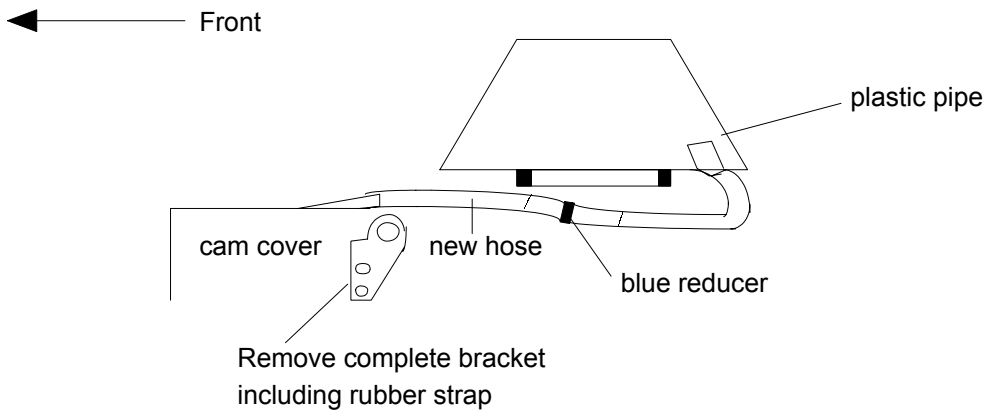

Drawing B

Continue the cut, using a hacksaw blade from the front

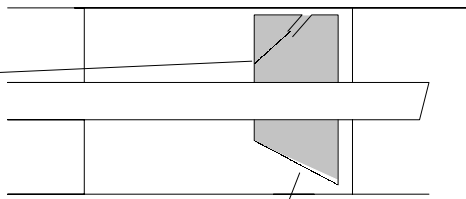

FRONT VIEW

Drawing C

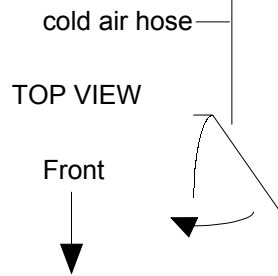

Having cut the two sections, bend the plastic flap towards the centre. This will give adequate space for the cold air hose to be located behind the grille.

Drawing D

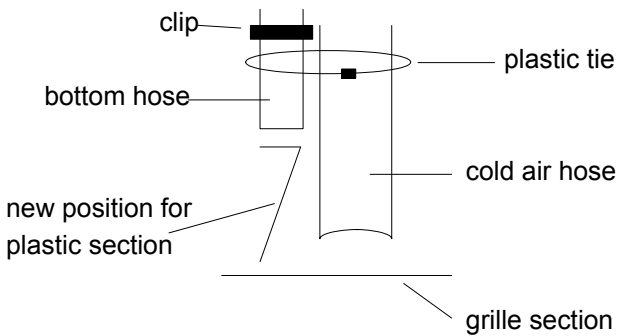

Drawing F

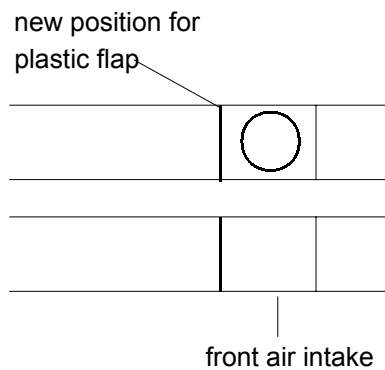

Drawing E

