

PLEASE READ THE INSTRUCTIONS BEFORE FITTING THE KIT
If you have a problem, however small, call our Technical Department.
Tel:- 01925 636950. Fax:- 01925 418948. Monday to Friday 9am - 5pm.

- 1 Remove the complete air box assembly including the inlet hose.
- 2 Remove the breather hose from the air box base.
- 3 Fit the new angled hose to the intake pipe with the cut-out aligned to the raised ridge on the inlet manifold and **firmly** tighten the clip. **Drawings A and C.**
- 4 Fit the metal tube up to the step in the filter neck and position the K&N Logo straight Tighten the clip until the filter just rotates, then give one full turn (360 degrees). No more. **Don't overtighten the clip.** **Drawings B and C.**
- 5 Position the breather hose as **drawing B.**
- 6 **Cold air system.**
Carefully expand the flexi hose to approximately 20"/50cm. Ovalise one end and feed this end through the original intake hole and into the front air intake. Using the long plastic tie, attach the hose to any convenient hose or pipe etc., as models vary. Position the cold air hose to finish approximately 10cm/4" from the filter (**no nearer**). **Drawings A and D.**
- 7 **Tuning**
We suggest that a simple **CO** test is carried out, as some cars may be set weaker than the standard setting. The **CO** figure should not be set at more than **0.5%** above the recommended figure.
- 8 **Filter maintenance**
Under normal conditions clean and reoil the filter at approx. 40,000 miles / 65,000 km. **Use only K&N cleaner and oil** and follow the instructions carefully.

K&N filters are pre oiled ready to fit

The advantages of K&N's cold air intake system

Cooler air, being denser, will show positive improvements in power over filter systems that draw hot air from the engine bay.

FITTING YOUR OWN 57i KIT

If not, **it is essential** that the person fitting the kit (e.g. mechanic) **carefully follows these particular instructions** even if he has fitted K&N kits before. This will save you both time and money. Kits incorrectly fitted may show a loss in performance e.g. the positioning of the essential cold air hose, (flexi expandable and rubber hoses are used).

A final check under the bonnet, by yourself, with the instructions, would seem sensible.

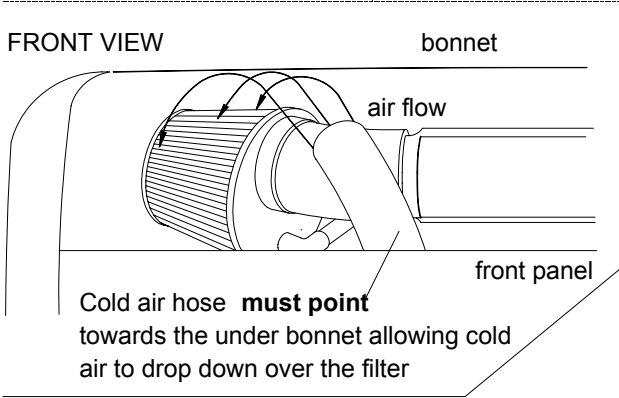
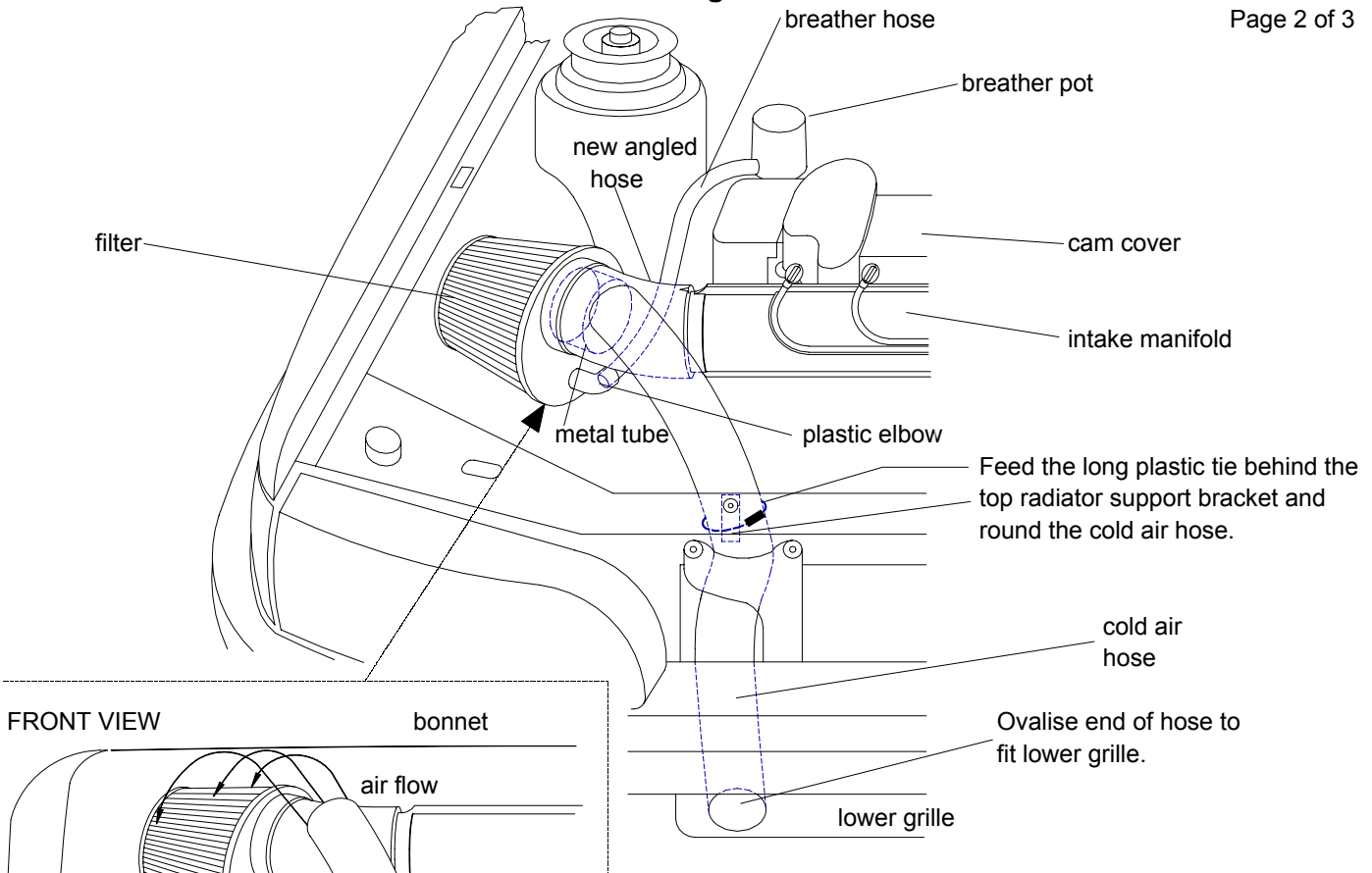

Fit the breather hose into the plastic elbow, and fit the elbow into the base of the filter.

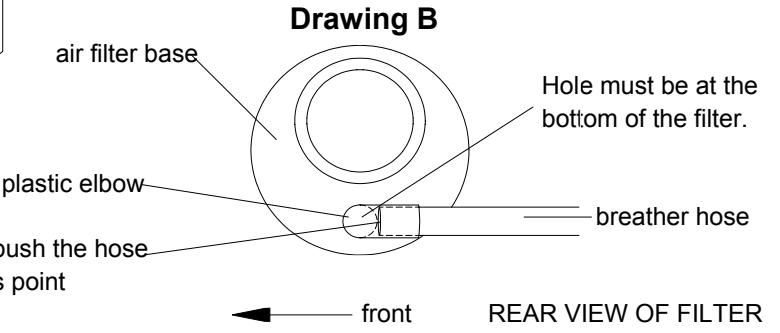

Push metal tube up to the step in the filter and tighten the clip. Do not overtighten the clip.

Drawing C

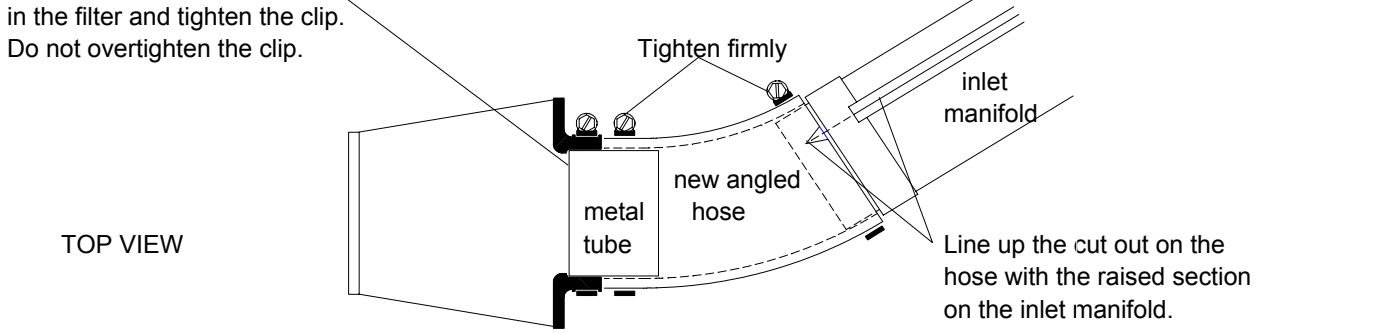

Drawing D

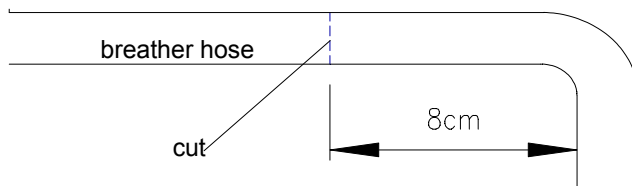

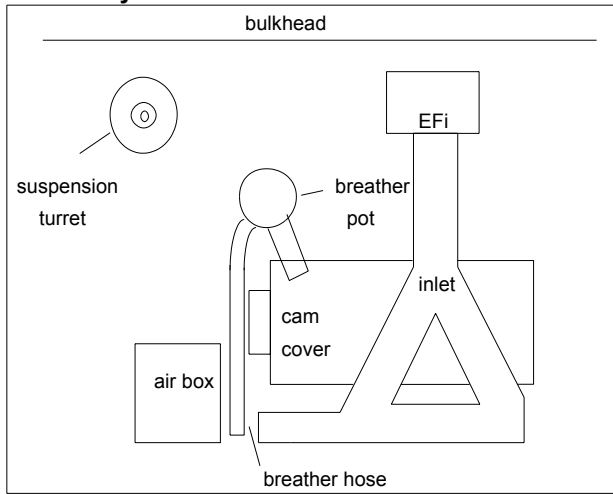
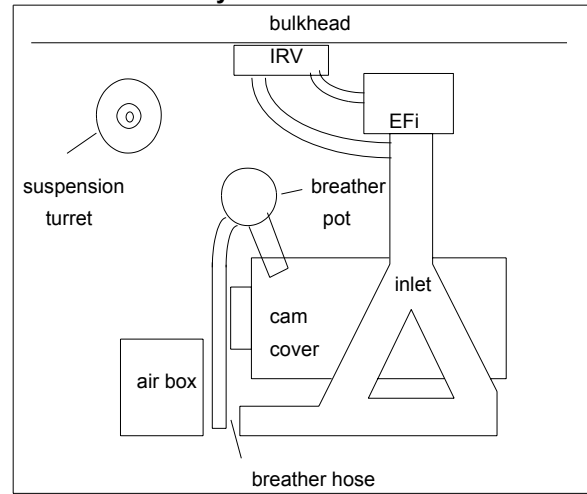
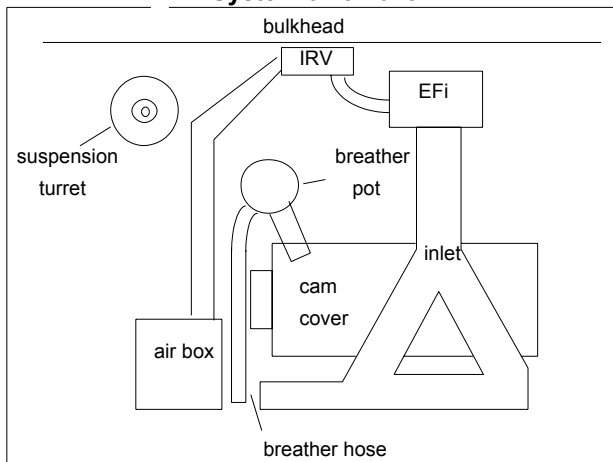
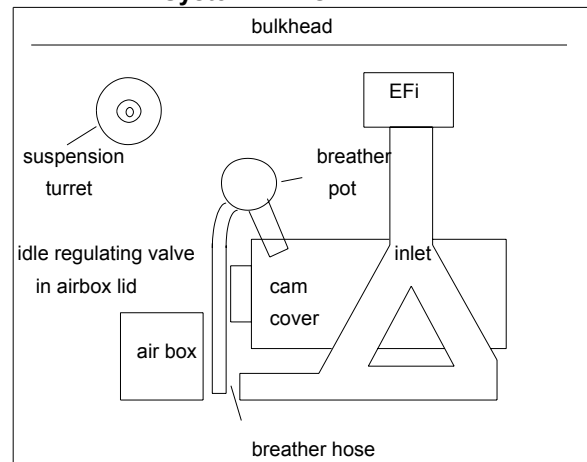
System 1 57-0015**System 2 57-0015****System 3 57-0131****System 4 NOT AVAILABLE****This Kit Should Contain :-**

- 1 x Clamp-on filter.
- 1 x Cold air hose assembly.
- 1 x Rubber intake hose.
- 1 x Instruction sheet.
- 1 x Instruction pack:-
 - 1 x Filter maintenance sheet.
 - 1 x K&N window sticker.
 - 1 x Million mile warranty card.
 - 1 x Leaflet.
- 1 x Fixing kit containing :-
 - 1 x Metal tube.
 - 1 x Hose clip size 44.
 - 1 x Plastic cable ties (14" long).
 - 1 x Plastic elbow.
 - 2 x Hose clips size 44.

**IMPORTANT INSTRUCTIONS
FOR ROUND ENTRY
CLAMP ON AIR FILTERS**

Gently tighten the hose clip to the point where the filter will just rotate on the pipe or intake flange.
Reposition the K&N logo straight, then give the clip two turns i.e. 360°, no more.